

System Design and Implementation of TDMA-Based WiFi Network

Rashid Saeed

Electronics Engineering Department, Engineering Faculty, Sudan University of Science and Technology (SUST), Sudan

Abstract: *The needs for bridging of digital divide in rural communities and the economics of currently available broadband access technologies motivate for innovate and deploy new system designs and applications. The widely available and flexible WiFi technique meets the cost and suitability targets for rural broadband applications. To cope with the special requirements of rural communication, amendments of 802.11 standards at the MAC protocol level has been introduced. These amendments were important due to the shortcomings of WiFi over long distances under the power constraints. This paper proposes a new 802.11 point-to-multipoint (PMP) technique based on TDD/TDMA technique, this by using one of the access points in the system as centralized/gateway point to the others APs. The discussion includes the TDMA design, architecture on top of the conventional 802.11 MAC. The protocol convergence at the gateway between the access network and the backhaul is also presented. The simulation results present the performance analysis and validate the efficiency of the proposed scheme.*

Keywords: PMP, TDMA, MAC, WiFi.

Received August 10, 2009; accepted March 9, 2010

1. Introduction

The needs of Internet and e-services for rural communities and remote sites using the available broadband access technologies motivate to innovate and deploy new systems design and applications. The widely available, and highly cost-reduced, WiFi hardware meets the cost target for rural applications. However, the current 802.11 MAC protocol does not designed to cope with such system, where it designed for local area network in indoor propagation environment [7].

In the long distance if WiFi SAT sends out data and due to propagation delay wait for an acknowledgment from the other radio that the data was received. If the transmitting radio doesn't receive the acknowledgment in a certain amount of time, it will assume that the data was lost, and it will resend it again. So using WiFi for long distances is needs some modifications in the MAC functionality. In this context, there are many works has been done using different criteria's and prospective. In [7, 12] Krishna *et al.* introduce a new design called Wireless Fidelity - Rural extension (WiFiRe) for rural broadband voice and data access, based on the WiFi PHY and WiMAX IEEE802.16 MAC layer, where a single channel multi-sector TDM MAC by employing directional antennas with simple scheduler are developed.

The combination of IEEE802.11b PHY and IEEE802.16 MAC is introduced in 2000 by the IEEE802.16.3 Wireless HUMAN [5] (Wireless High-speed Unlicensed Metropolitan Area Networks) to get the advantages of the availability, low cost chipsets and

license-free WiFi devices and well-designed WiMAX MAC with Quality of Service (QoS) [1]. WiFiRe is support maximum 25Mbps data rate in the DL by using two parallel sectors transmissions. The design was tested using VOIP simultaneous calls in all STAs, the throughput was improved about 3.5 times the conventional IEEE802.11b [11]. R. Patra *et al.*, in [9] presents WiLDNet WiFi-based Long Distance (WiLD) networks with mesh link configuration has the potential to provide connectivity at lower costs than traditional approaches based on IEEE802.11 with several essential changes to the 802.11 MAC protocol, but continues to rely on standard WiFi network cards. WiLDNet used an adaptive loss recovery mechanism using FEC and bulk acknowledgements to cope with the high propagation delay. Controlled Channel Access (HCCA) and Enhanced Distributed Channel Access (EDCA) are introduced in IEEE 802.11e to enhance the QoS over WiFi [6, 8]. In [10] Guo and Tzi proposed enhancement work to EDCA and HCCA using software-based TDMA algorithm for indoor enterprise WLANs applications. They propose a solution for VOIP frames QoS by eliminates the back-off overhead. QoS topics are out of this paper scope.

This paper presents the modifications of IEEE802.11 wireless local area network from contention-based access to contention-free access, where a Point-to-Multipoint (PMP) -based TDD/TDMA technique on each (downlink) carrier is discussed. The protocol signaling and control messages are also discussed, where a new cross layer approach is introduced to transport feedback

dynamically via MAC and TDMA layers boundaries to enable the compensation of the overload, latency and other mismatch between the two protocols by modify 802.11 MAC protocol parameters i.e., Network Allocation Vector (NAV), SSID and packets encapsulation. The discussion includes the key issues of MAC system and architecture design and performance analysis for the protocol conversion including throughput, packet loss and TDMA slot time.

2. Network Backhaul Design and Configuration

The objective of this broadband PMP Access system is to provide wireless broadband access to the operator service nodes i.e., Point of Presence (PoP) to remote customer locations. As shown in Figure 1, each remote location is served by a peripheral station that is able to offer a variety of service interfaces to end users [13]. These peripheral stations (i.e., AP) has two-way full duplex radio link to centralized station with PMP capability (i.e., BS-node). The BS-node has two interfaces, one is the WiFi-based PMP access to the APs and the second is to WiMAX core network. Subscribers are transparent of the BS-node which is means it can connect to the APs through various network interfaces (i.e., Ethernet, WiFi, dial-up, etc.) [2]. The system allows services to be provided to a number of subscribers, ranging from a few tens to many hundreds of users in the same rural area, and over a wide range of distances. In this paper our scope is to design the WiFi-based PMP backhaul network.

The system will allow PMP topology based on IEEE802.11 to cover wide highly populated metropolitan or sparse rural areas collecting various kinds of services [9]. Moreover, with the PMP scenario each area, served by a distributed system comprises of one central AP (BS-node) and many other APs distributed as hotspot manner to connect the stations STAs to the Internet.

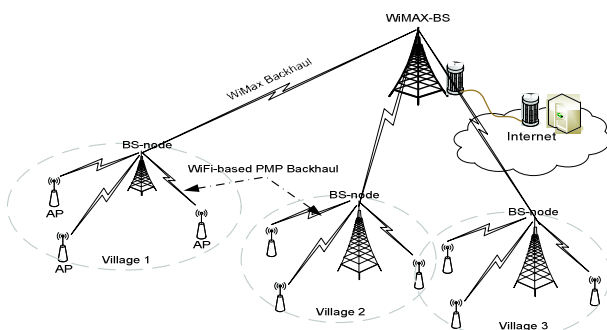

Figure 1. Wireless broadband network architecture.

Each AP is equipped with a high gain directional antenna in line or non-line of sight with the BS-node. It receives the multiplexed traffic channels and demultiplexes the information directed to the user served by the AP [11]. In its time slot APs transmits back to

the BS-node, on a separate frequency (uplink), traffic and signalling information. Uplink transmission is slot based TDMA that is each AP is assigned a time slot to transmit in the TDD frame. One BS-node can support up to 50 Mbps of traffic payload per direction per sector [3].

3. Design of TDMA Algorithm

IEEE802.11 has two modes DCF and PCF. Distributed Coordination Function (DCF) relies on CSMA/CA distributed algorithm and an optional virtual carrier sense using RTS and CTS control frames [4]. If the channel is busy during the DIFS (DCF Interframe Space) interval, the station defers its transmission. Point Coordination Function (PCF) is used for “infrastructure” mode, which provides contention-free frame transfer for processing time-critical information transfers [12]. PCF is optional in the standard and only few vendors implemented it in their adapters. Two different periods defined at PCF mode: Contention-Free Period (CFP) and Contention Period (CP). CFP uses contention free-poll frames to give stations the permission to transmit. However, PCF has many drawbacks and limitations in long distance applications (i.e., up to tens of kilometers) this due to sensitivity of the Acknowledgement (ACK) messages to propagation delay which is designed for contention-free local area networks purposes. Also, once a station reserves the access to the medium, it may occupy the medium for long time without any station can interrupt its transmissions even in the high priority traffics case, i.e., if the remote station has lower data rate due to the distance, then it will take long time to release the channel [13].

Consequently, it has been shown that [2, 3] TDMA-based MAC is suitable for long distance propagation delay. Most of the implemented solution for long distance WiFi-based network was used WiMAX like TDMA frame for conducting the PMP scenario. However, using WiMAX/TDMA above WiFi is increasing the system complexity and overhead since the WiMAX/TDMA has been built for the licensed-based and WiFi is built with unlicensed environment. In this paper a design of TDMA over the 802.11 is presented. The function of the proposed TDMA is to disable the contention behaviour of 802.11 (CSMA/CA) for contention-less MAC. In this paper a new cross layer design is introduced between CSMA/CA and new logical TDMA layer, which the WiFi MAC frame is encapsulated in a logical TDMA header before forwarded to IP layer. The proposed protocol stack is shown in Figure 2. The CSMA/CA peer-to-peer protocol is disabled and replaced with TDMA peer-to-peer protocol as shown with the dot-lines. The logical TDMA header is added between IP header and MAC header. The function of the new header is to disable the random access feature of the

CSMA/CA in 802.11 and replace it by logical TDMA function, which is maintains the synchronization of the local timers in the stations and delivers protocol related parameters. The frame is shown in Figure3. The proposed TDMA header contains BCCH (broadcast control channel), FCCH (frame control channel) and RA (random access). The full flowchart for the TDMA-MAC Protocol is in Figure 4.

Figure 5 illustrates the flow of the virtual channels for the uplink and downlink of the TDMA frame:

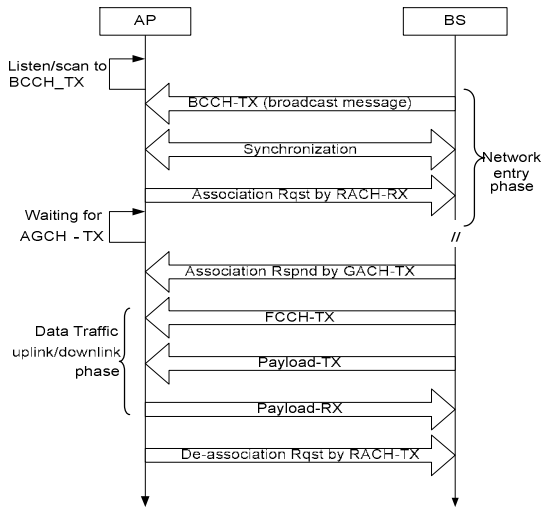

Figure 2. Protocol flow of the TDMA-based PMP.

1. BCCH: Contains general information i.e., timestamp through `time_stamp_update()`, SSID, BS-node capabilities and random access time interval `ra_interval()`. All this parameters (except the RA time interval) is prepared and copied from the beacon frame (using `beacon_content()`) from the WiFi MAC device driver. The BCCH information helps the APs in the sleep, wakeup, transmitting and receiving times.
2. FCCH: Carries the information about the structure and format of the ongoing frame i.e., `scheduler()` and `time_slot_builder()`, containing the exact position of all slots and Tx/Rx times and guard time between them and scheduling.
3. RA: Contains a number of random access channels (RCH). This field is uses when no schedule has been assigned to the APs in the UL fields. Non-associated APs use RA for the first contact with an AP using `slot_time_request()`. The flow diagram of logical control and data channels is shown in Figure 4.

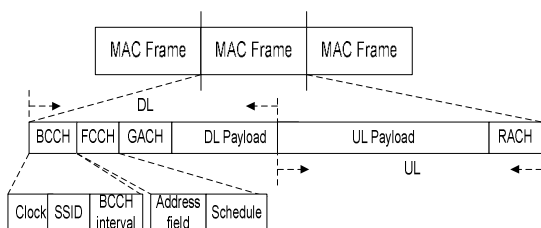

Figure 3. Additional TDMA header is added to WiFi frame.

First, the RACH frame to be received if there is any connection request from APs to BS. Then, BCCH, FCCH and AGCH broadcast their information, then transmit and receive user's payload. Timer is controlling all the transmitted and received signals.

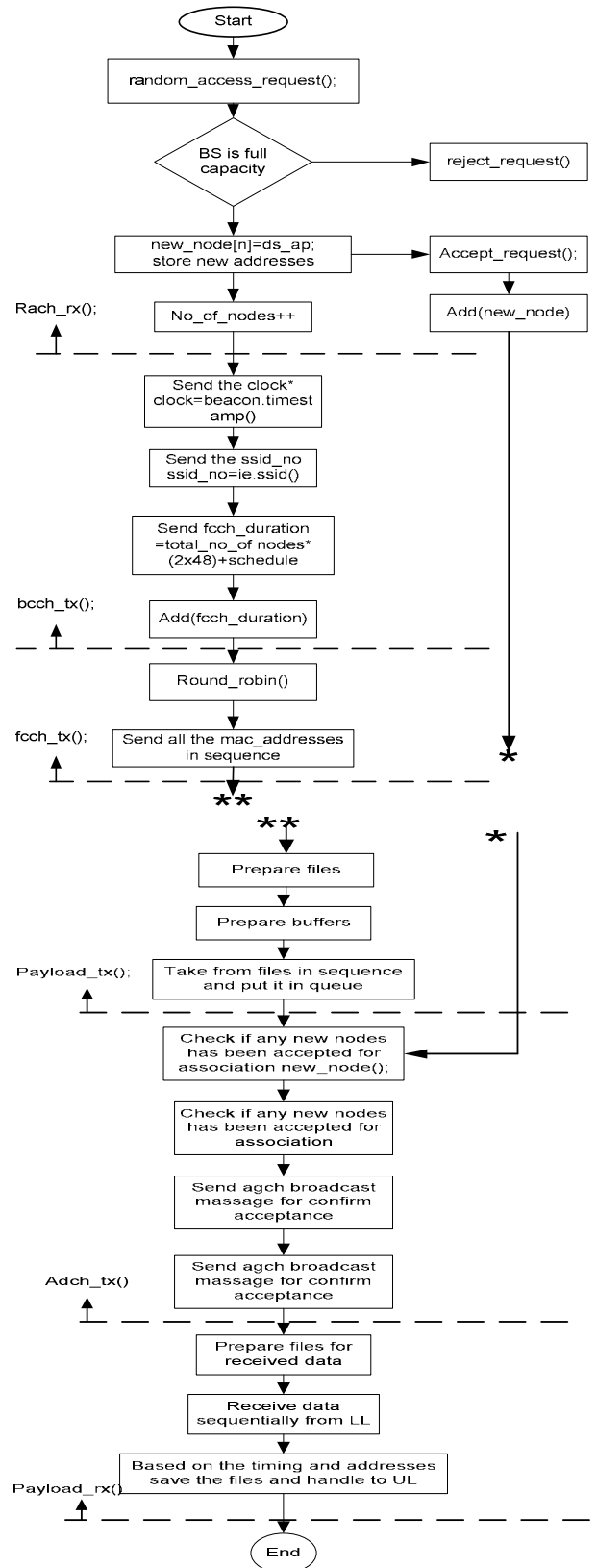

Figure 4. Flowchart for the TDMA-MAC protocol.

The new TDMA header is introduced at the cost of the performance due to the overhead. However, in the long distance applications with point-to-multiple-point infrastructure scenarios usually the numbers of stations are not too high compared with end-user part. In our scenario we consider 3 remote access points and one central access point (BS-node).

By implementing TDMA_module() each APs would assigned with time slot within the TDMA frame. TDMA also saves power because each STA only needs to wake-up during these time slots in each frame. If new node (AP) wants to join the network it listens to the BCCH frame to get the initial parameters from the BS-node. Then it uses the RA period to send time_slot_request() request to the BS-node to request for time slot. The BS-node uses the FCCH field to update the new scheduling table in scheduler().

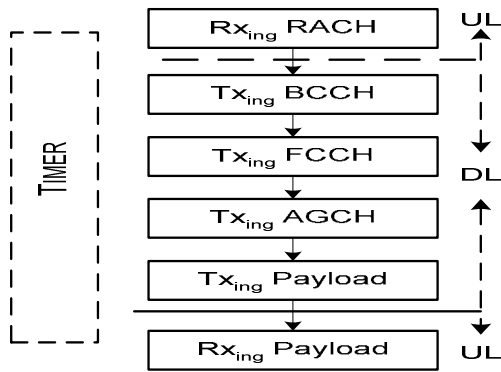

Figure 5. The flow of the virtual channels for the TDMA frame.

The TDMA_module() assigns time slots for APs by taking copy of the NAV (network allocation vector) information (NAV_update()) from the WiFi MAC layer and modifying it according to the schedule scheme. NAV is considered as virtual carrier sensing which is limits the need for contention-based physical carrier sensing. This is done by setting new back_off_counter() and NAV_new() in the TDMA_module() which indicates the amount of time that medium will be reserved for each time slots. The BS-node set the NAV value to the frame length time plus any other necessary messages to complete the current operation to make sure that no station (AP) will access the channel during the frame transmission.

Other stations count down from the NAV to 0. When the NAV has nonzero value, the scheduler() send back to the WiFi MAC that indication that the medium is busy; before the NAV reaches 0, the back_off() and NAV_new() update the WiFi MAC with the new NAV. The Destination Address (DA) and Source Address (SA) in the MAC frame header and in the SSID is modified according to the new NAV and RR scheduling information. Figure 6 shows the flow of the process in cross-layer concept.

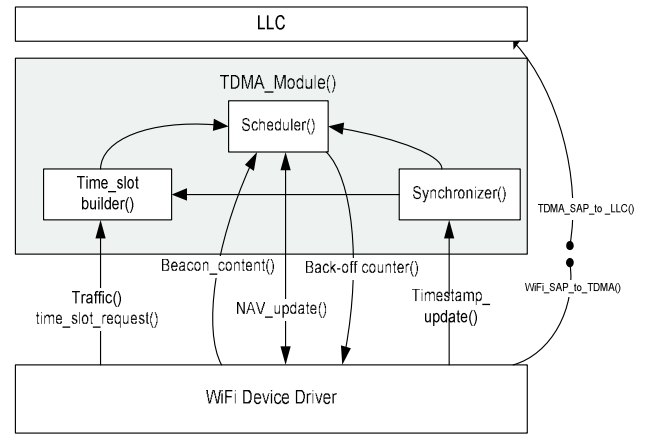

Figure 6. Cross-layer design for TDMA-based MAC.

4. Simulations and Configurations Setup

Simulations are conducted using ns2.33. Scenario with four WiFi nodes is used in the simulation setup. Node0 is configured as TDMA BS-node which is control the TDMA frame and performs scheduling for the other three nodes (node1, node2 and node3). The BS-node is allocated at central point and the other APs distributed around and in the range of it; so we used Omni-directional antenna for this purpose. The simulation configuration parameters are shown in Table 1. Queuing and QoS are out scope of this paper, for simplicity and without loss of generality, in the simulation a simple Round Robin (RR) is used, where each station has slot in the frame. However any TDMA QoS scheme can replace round robin. Node 0 is configured as BS-node, while the other three nodes (node1, node2 and node3) configured as fixed-nodes. BS-node is working as a gateway between WiFi and WiMAX to the Internet and it allow packets to be exchanged between the two networks. In the simulation, we add TCP traffic generator for each node so each node can send the traffic within the time slot allocated and assigned to it in the TDMA frame.

Table 1. Simulation design and performance parameters.

Parameters	Value
CWmin (The min size of the CW, in units of a slot time)	15
CWmax (The max size of the CW, in units of a slot time)	1023
Rx/Tx switch time	10 μs
CCA time	27 μs
TXRX turnaround time	10 μs
Frame length	20ms
Guard time between UL and DL	20 μs
Random access time	20 μs
NAV update	10ms
Time slot	500μs
Max data length allowed in one slot (byte)	1500
Max number of slots in one frame	32
Energy detect time	15μs

Figure 7 shows the normalized throughput versus the random packet loss rate for different access time for the NAV update. The figure shows that the cross layer between the TDMA new layer and WiFi MAC

layer reduces the throughput dramatically. However, if the NAV time does not updated frequently (at least each frame time) leads to increase the interference due to the random nature of the lower layers of the CSMA/CA (MAC and PHY).

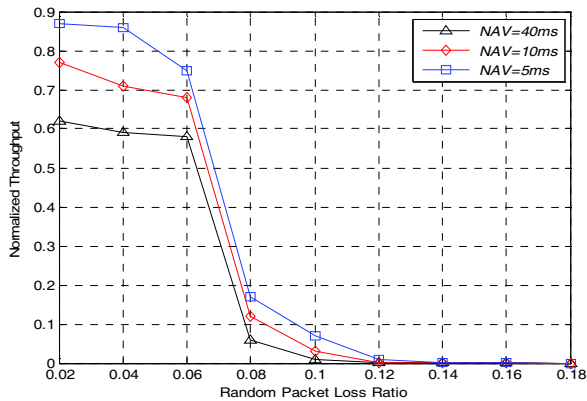

Figure 7. Normalized throughput and the random packet loss rate for different access time for the NAV update.

Figure 8 shows the throughput for the TDMA network for five different values of time slots (4, 8, 16, 32 slots). The throughput first decreases with the number of nodes and then increases slightly due to optimized points between the number of users and number of slots, where it is the case that there is no zero padding in the frame. The throughput again starts decreases after the small and quick jump. So the number of slots and number of nodes is designed before start transmission. The BS-node shall set the TDMA header with variable a slot_time for flexible adaptive association/reassociation nodes in the network.

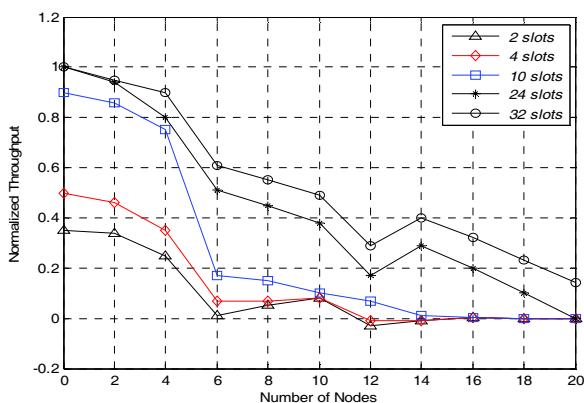

Figure 8. The normalized throughput vs number of nodes for different number of slot.

In Figure 9, we varied time slot size between 0.1ms to 0.8ms, the packet loss ratio shows linear behaviour between 0.8ms to 0.3ms. Also the figure shows that below 0.2ms time slots size, any slight change in the time slot size increases the packet loss ratio. So, as a result the optimum time slot size should be between 0.3ms to 0.8ms. Here in we choose to use 0.5ms as the optimum point for the slot size.

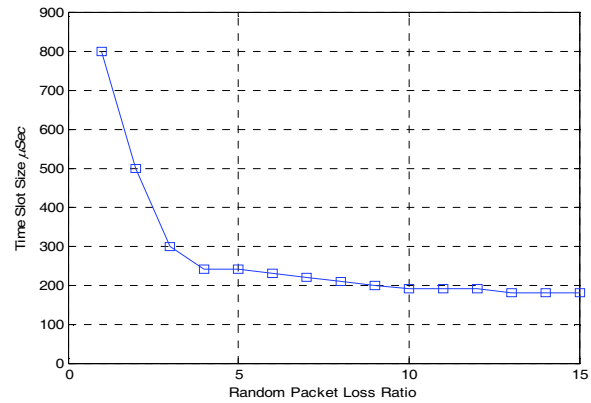

Figure 9. Time slots size vs. the packet loss ratio.

5. Conclusions

In outdoor long distance applications e.g., video streaming from traffic light cameras or Internet distributed network in rural areas, IEEE802.11 MAC protocol has fundamental shortcomings that CSMA/CA is fail to work well due to the high propagation delay, which is designed for indoor short distance applications.

This paper presents cross-layer PMP-based TDMA network using 802.11 lower layers. The discussion includes the key issues of MAC design, architecture and performance analysis i.e., throughput for different access time for the NAV, time slot size and number of nodes. The achieved performances validate the efficiency of the proposed scheme.

References

- [1] Qualcomm Atheros, Super G Maximizing Wireless Performance, available at: <http://www.atheros.com/pt/papers.html>, last visited 2010.
- [2] Bhaskaran R., "Digital Gangetic Plains: 802.11-based Low-Cost Networking for Rural Areas," *Technical Report*, Department of Computer Science and Engineering, Indian Institute of Technology, Kanpur, 2005.
- [3] Fanglu G. and Tzi-cker C., "Software-Based TDMA for VoIP over Wireless LAN," in *Proceedings of 26th IEEE International Conference on Computer Communications*, USA, pp. 2366-2370, 2007.
- [4] Gu D. and Zhang J., "Evaluation of EDCF Mechanism for QoS in IEEE802.11 Wireless Networks," in *Proceedings of World Wireless Congress*, UK, pp. 1498-1510, 2003.
- [5] IEEE802.16 Wireless HUMANTM Study Group, Wireless High-Speed Unlicensed Metropolitan Area Network Standards Public MAN for Broadband Fixed Wireless Access in License Exempt Bands, available at: <http://wirelessman.org/human/>, last visited 2000.
- [6] IEEE802.11e, "IEEE Standard for Information Technology-Telecommunications and

Information Exchange between Systems-Local and Metropolitan Area Networks-Specific Requirements Part 11: WLAN MAC and PHY Specifications: MAC Quality,” 2005.

- [7] Krishna P., Anitha V., Sridhar I., Bhaskar R., and Anurag K., “WiFiRe Rural Area Broadband Access using the WiFi PHY and a Multisector TDD MAC,” *IEEE Communications Magazine*, vol. 45, no. 1, pp. 111-119, 2007.
- [8] Neufeld M., Fifield J., Doerr C., Sheth A., and Grunwald D., “SoftMAC-Flexible Wireless Research Platform,” in *Proceedings of 4th Workshop on Hot Topics in Networks*, USA, pp. 1-15, 2005.
- [9] Pravin B., Bhaskaran R., and Dheeraj S., “Turning 802.11 Inside-Out, Second Workshop on Hot Topics in Networks,” in *Proceedings of Second Workshop on Hot Topics in Networks (Hot Nets-II)*, USA, pp. 15-849, 2003.
- [10] Rabin P., Sergiu N., Sonesh S., Anmol S., Lakshminarayanan S., and Eric B., “WiLDNet: Design and Implementation of High Performance WiFi Based Long Distance Networks,” in *Proceedings of 4th Usenix Symposium on Networked Systems Design and Implementation*, India, pp. 87-100, 2007.
- [11] Sharma N., Zhu G., Peng D., and Chiueh T., “Implementation Experiences of Bandwidth Guarantee on a Wireless LAN,” in *Proceedings of ACM/SPIE Multimedia Computing and Networking*, India, pp. 99-108, 2002.
- [12] Sridhar I., Krishna P., Anurag K., and Bhaskar R., “WiFiRe Medium Access Control and Physical Layer Specifications,” *Technical Report of CEWiT*, India, pp. 1-110, 2006.
- [13] Wu H., Wang X., Liu Y., Zhang Q., and Zhang Z., “Softmac Layer 2.5 MAC for VOIP Support in Multi-Hop Wireless Networks,” in *Proceedings of IEEE SECON*, Italy, pp. 441-451, 2005.



Rashid Saeed received his PhD majoring in communications and network engineering from University Putra Malaysia (UPM), Malaysia in 2007. He was a senior researcher at Telekom Malaysia™, Research and Development Innovation Centre from 2008 to 2010, and a senior researcher at MIMOS Berhad from 2007 to 2009. Currently, he joins the school of electronics engineering, Sudan University of science and technology (SUST). Dr. Rashid has been published more than 100 research papers/tutorials/book chapters on wireless communications and networking in peer-reviewed academic journals and conferences. He has successfully filed 13 patents 2 of them were in U.S. He is Senior MIEEE since 2001 and Sigma Xi. His research interests are in the areas PHY/MAC cross layer design in UWB, WiFi and WiMAX.